

(No Model.)

D. S. COOKE & J. HAGERTY.

MACHINE FOR COMBINING THE BACKS AND FRONTS OF ARTICLES OF JEWELRY.

No. 254,117.

Patented Feb. 28, 1882.

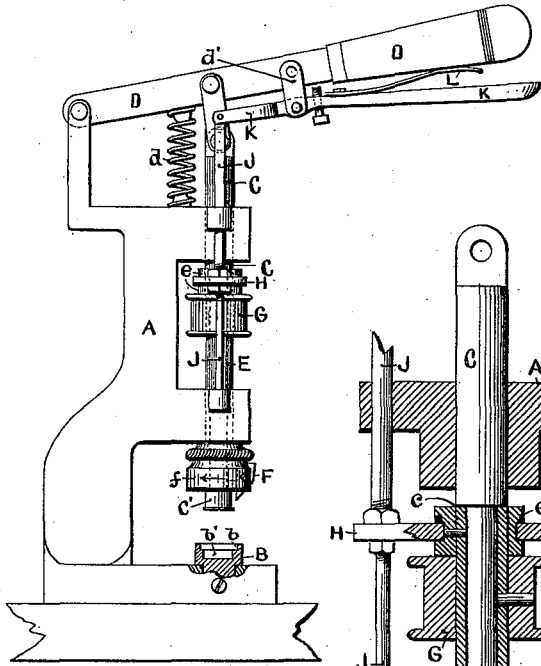

FIG. 1.

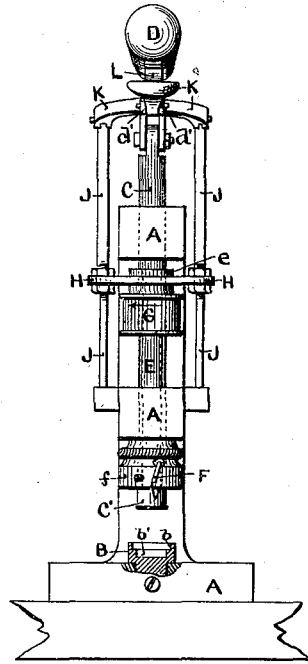

FIG. 2.



FIG. 5.

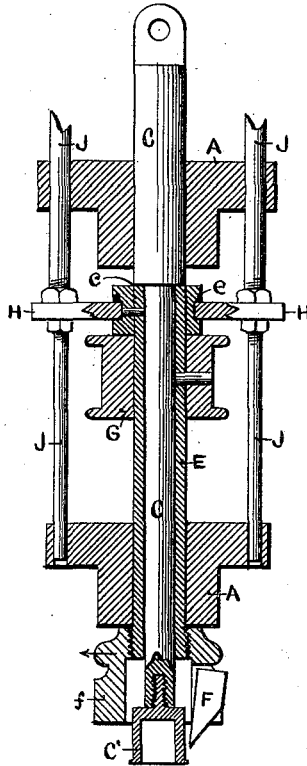

FIG. 3.

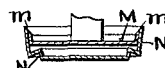

FIG. 6.

WITNESSES:

*Henry J. Stapleton*  
*W. H. Peterson*

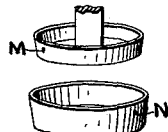

FIG. 4.

INVENTOR:

Daniel S. Cooke,  
 John Hagerty,  
 by *Edson Salisbury Jones*  
 Attorney.

# UNITED STATES PATENT OFFICE.

DANIEL S. COOKE AND JOHN HAGERTY, OF PROVIDENCE, RHODE ISLAND;  
SAID HAGERTY ASSIGNOR TO SAID COOKE.

MACHINE FOR COMBINING THE BACKS AND FRONTS OF ARTICLES OF JEWELRY.

SPECIFICATION forming part of Letters Patent No. 254,117, dated February 28, 1882.

Application filed October 29, 1881. (No model.)

To all whom it may concern:

Be it known that we, DANIEL S. COOKE and JOHN HAGERTY, of the city and county of Providence, and State of Rhode Island, have jointly invented a new and useful Improvement in Machines for Combining the Backs and Fronts of Articles of Jewelry; and we do hereby declare that the following specification, taken in connection with the accompanying drawings, forming a part of the same, is a full, clear, and exact description thereof.

Our improvement consists in a machine adapted to combine the back plate of a circular article of jewelry with the face member thereof, and to cut or burr the edges of the back plate and the rim of the face member on a bevel, so that said rim may be readily burnished or turned over upon the back plate to hold the parts against separation.

Machines have heretofore been constructed for forcing the back plate into the rim of an article of jewelry; but the cutting or burring of the edges of the back plate and rim preparatory to turning the latter over upon the former (which operation of burring is desirable to facilitate the folding of the rim and to produce a more finished appearance) has been performed, as far as we are aware, on a separate machine or lathe and with a hand-tool.

The object of our improvement is to combine the backs and fronts and cut or burr the edges of the same on one machine, and to perform the latter operation by a power tool, thereby facilitating and reducing the cost of manufacture.

Referring to the drawings, Figures 1 and 2 show respectively side and front elevations of our improved machine. Fig. 3 represents, on an enlarged scale, certain details of construction. Fig. 4 shows, in perspective, the back and face members of a circular button before the same are combined. Fig. 5 represents, in section, said parts combined; and Fig. 6 shows, in section, said parts combined and their edges beveled.

A is the frame of the machine, which is provided with a die, B, for receiving the face member of an article of jewelry. This die is provided with a shoulder, *b*, for supporting the face member, and is also preferably supplied with a central cavity, *b'*, to accommodate any

projection on the face of the article—such as a stone or raised ornament.

C is a plunger, which is preferably linked to a lever, D, the said parts being upheld by a spring, *d*. The lower end of the plunger is provided with a member, C', which is preferably supplied with a central cavity to receive any projection from the back of an article of jewelry—such as the post of a button. The die B and member C' are detachable, in order that different sizes of these parts may be used, although the die may form a part of the frame and the member C' a part of the plunger proper.

Mounted on the plunger C is a sleeve, E, whose lower end is supplied with a cutting or burring tool, F, properly mounted in a hub, *f*, secured to the sleeve, and said sleeve is provided with a pulley, G, secured thereto, for rotating the sleeve and its cutter. The upper end of the sleeve E is supplied with a grooved collar, *e*, which is engaged by a yoke, H, secured to rods J J, which slide in the frame of the machine. The upper ends of these rods are pivoted to the forked end of a lever, K, which lever may be pivoted to the frame of the machine at any convenient point, but is preferably connected to the lever D by a link or links, *d'*, as shown in Fig. 1, in order that both of said levers may be conveniently manipulated by one hand. A spring, L, is placed between the levers D K and bears upon the same, the said spring, through the lever K, rods J J, and yoke H, operating to hold the cutter on the sleeve E above the lower end of the member C' on the plunger at all times except when the lever K is pressed by the hand. The spring L (which may be placed in any other proper position, if desired) also brings the upper end of the sleeve E into engagement with a shoulder, *c*, on the plunger, as shown in Fig. 3, in order that the sleeve shall move downward with the plunger and thereby prevent loss of time in bringing the cutter to its work.

The operation of the machine is substantially as follows: Suppose the back plate, M, and the face member, N, of a sleeve-button—such as shown in Figs. 4, 5, and 6—are to be combined. The face member, N, is placed in the die B, so as to be supported by the shoulder *b*, and the back plate, M, is placed in the

face member; or the said parts may be put together before being placed in the machine. The lever D is now pressed, causing the plunger C to move downward and force the back plate into the face member, as shown in Fig. 5. Owing to the engagement of the shoulder *c* on the plunger with the end of the sleeve E, the latter will move downward with the plunger. While the plunger is yet in engagement with the back plate, M, (to prevent rotation of the button during the burring operation,) the revolving sleeve E and its enter F are moved downward by pressure applied to the lever K, and the cutter is brought into engagement with the edges of the back plate and rim of the face member and the same are cut or burred on a bevel, as shown at *m* in Fig. 6. The pressure upon the levers is now withdrawn and the springs return the parts to their normal positions.

We are aware that the construction of the machine may be varied without departing from the spirit of our invention—as, for instance, the rods J J and yoke H may be dispensed with, and the forked end of the lever K be made to engage the collar *e* on the sleeve. The links on the plunger may be dispensed with and the end of the plunger C be brought into contact with the lever D, and the spring *d* be arranged to hold the plunger and lever in engagement, and the sleeve E may be arranged to move downward entirely independent of the plunger C.

What we claim as our invention, and desire to secure by Letters Patent, is—

1. The combination, substantially as herein set forth, of a stationary die for supporting the work, a plunger adapted to co-operate with said die, as described, a rotating and sliding sleeve mounted on said plunger and provided with a cutting-tool, and suitable means, as described, for moving the plunger and sleeve to and from the die.

2. The combination, substantially as herein set forth, of a stationary die for supporting the work, a plunger adapted to co-operate with said die, as described, a rotating and sliding sleeve mounted on said plunger, engaging a shoulder on the same when in normal position, and provided with a cutting-tool, a lever for moving the plunger and sleeve simultaneously toward the die, a second lever for giving the sleeve a further movement toward the die independently of the plunger, and suitable means, as described, for retreating the parts.

3. The combination, substantially as herein set forth, of a stationary die for supporting the work, a plunger adapted to co-operate with said die, as described, a rotating and sliding sleeve mounted on said plunger and provided with a cutting-tool, a lever for moving the plunger toward the die, a second lever connected with the sleeve and with the first lever for moving the sleeve and cutting-tool up to the work, and suitable means, as described, for retreating the parts.

4. The combination of the stationary die B, the plunger C, the sleeve E, adapted to hold a cutting-tool, F, the lever D, the lever K, connected with the sleeve E and with the lever D, and springs for retreating the plunger and sleeve, substantially as set forth.

5. The combination of the detachable die B, having a shoulder, *b*, and cavity *b'*, the plunger C, provided with a detachable member, C', having a central cavity, the sleeve E, adapted to hold a cutting-tool, F, and provided with a pulley, G, the levers D K, the rods J J, yoke H, and springs *d* L, substantially as described and shown.

D. S. COOKE.  
JOHN HAGERTY.

Witnesses:

EDSON SALISBURY JONES,  
FRED. W. CADY.